

FLUID HANDLING

Mobile Equipment-Hydraulic Kits

A system that provides filtration of hydraulic oil with the use of depth media for a constant contamination control solution at very low ISO cleanliness levels.



FEATURES

- Dedicated depth filtration for constant contamination control
- Heavy-duty, industrial designed canisters ideal for harsh environment



Specifications

The Hydraulic Kit: Where It's Used

- Loader hydraulic systems
- Dozer hydraulic systems
- Haul truck hydraulic systems
- Off-road mobile hydraulic systems and transmissions

Selecting the Appropriate Model:

- Up to 150 gallons of oil: HYD-1
- 151 or more gallons: HYD-2

Features for Each Model Include:

HYD-1

- 1 - 1000 swing bolt lid filter canister
- Includes (1) 4 part, size 1000 depth filter element designed for hydraulic fluid
- ¼" & ½" NPT plumbing connections
- 0.5gpm flow control valve
- 50psi pressure relief valve

HYD-2

- 2 - 1000 swing bolt lid filter canisters
- Includes (2) 4 part, size 1000 depth filter elements designed for hydraulic fluid
- ¼" & ½" NPT plumbing connections
- 0.5gpm flow control valve
- 50psi pressure relief valve

NOTE: Customer to supply hose and fittings needed for machine connections.

How It Works:

Oil flow will originate from a constant pressure point in the hydraulic system. A pressure compensated flow control valve is installed at the inlet of the filter canister to meter flow into the hydraulic system.

Oil will flow through the hydraulic kit at the set rate and be returned to the reservoir. A pressure relief valve is also installed in the canister and returns to the reservoir to prevent accidental over pressuring of the canister.

Flow Diagram:

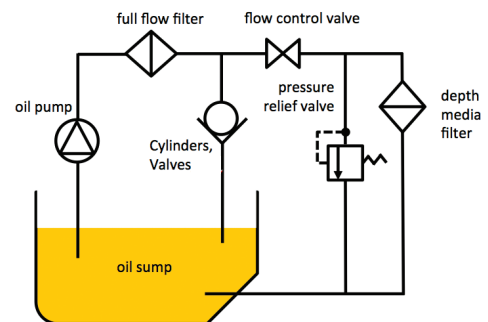

Particulate Removal Filter Media

Wound Cellulose Depth Media

Features Include:

- High-efficiency filtration at very low micron levels (≤ 1 micron)
- Ideal for filtering petroleum-based fluids
- Performance to $\beta_{<3}(c)=1000$ (per ISO 16889)
- Dirt holding capacity up to 10lbs per element
- Absorbs up to 1 gallon of water per element
- Can maintain moisture levels below 50ppm